

## Azionamento - Actuation

### Azionamento singolo con doppia attivazione Single actuation with dual activation

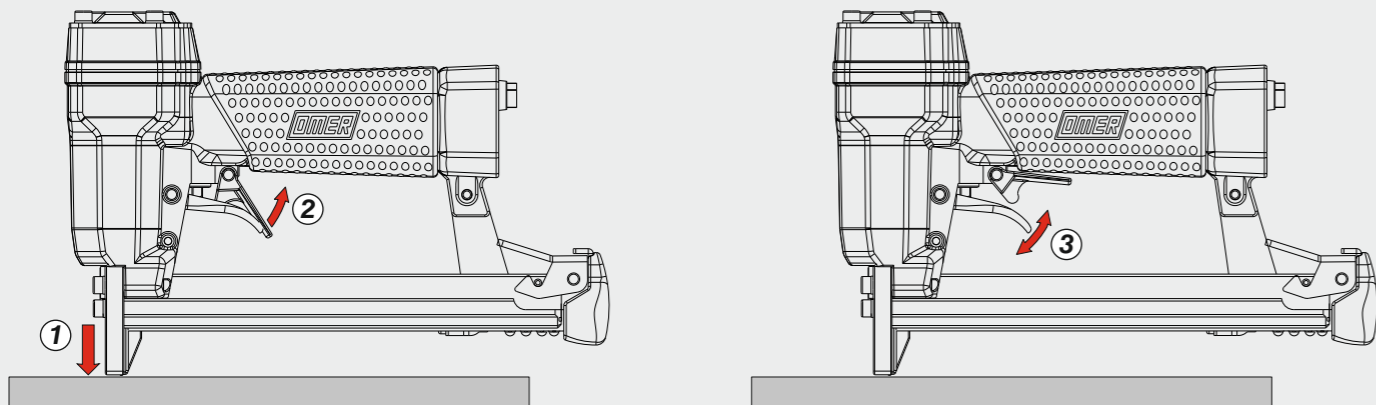

## Caricamento - Loading

### Caricamento da sotto Bottom load magazine

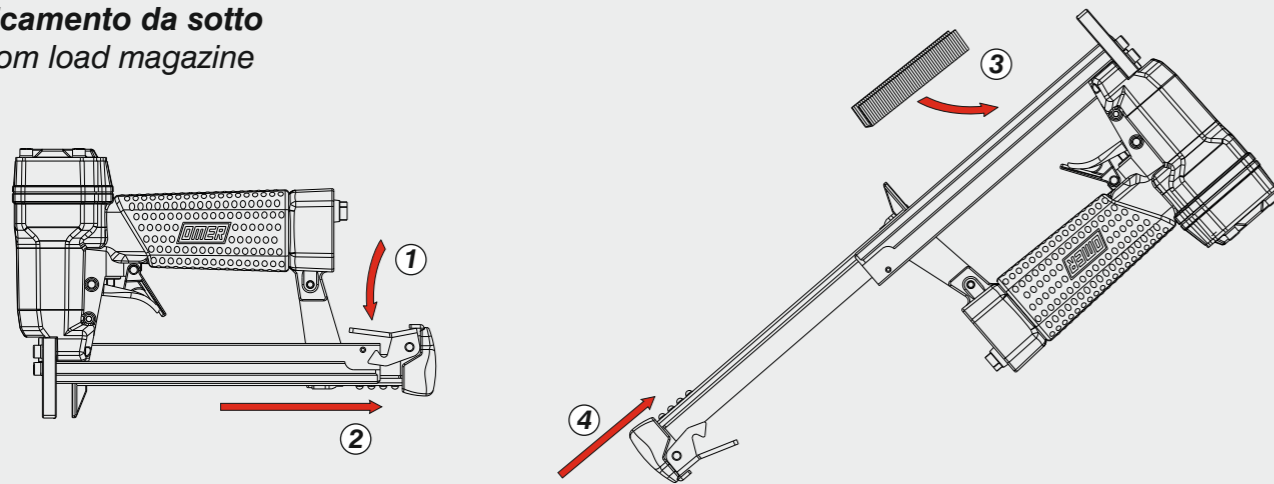

## Disinceppamento - Jam clearing

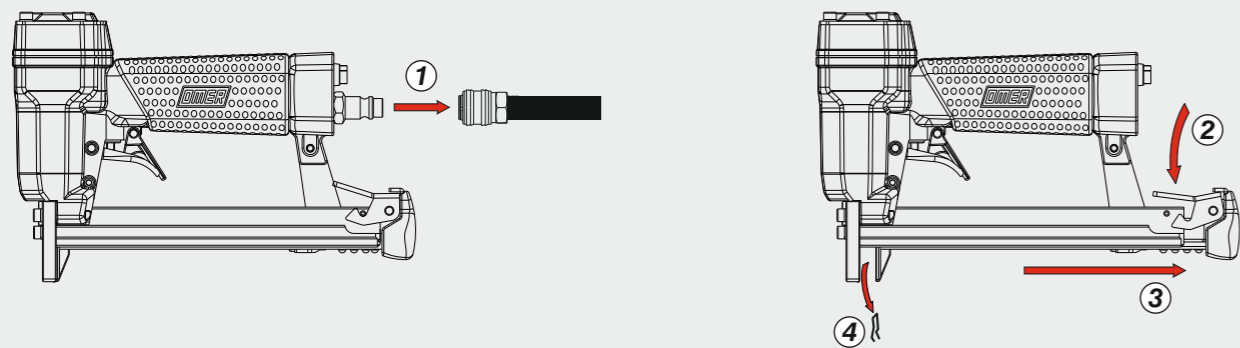

**OMER**®

**Manuale d'uso, manutenzione e parti di ricambio**  
**Use, maintenance and spare parts manual**  
**Gebrauchsanweisung, Instandhaltungsrichtlinien und Ersatzteile**  
**Manuel d'utilisation, entretien et pièces de rechange**  
**Manual de uso, mantenimiento y repuestos**  
**Εγχειρίδιο χρήσης, συντήρησης και ανταλλακτικών**  
**Manual de utilização, manutenção e partes sobresselentes**  
**Handleiding voor gebruik, onderhoud en wisselstukken**  
**Brugsanvisning, vedligeholdelse og reservedelsliste**

**Parte 2**  
**Part 2**  
**Teil 2**  
**Partie 2**  
**Part 2**  
**2° Μέρος**  
**Parte 2**  
**Deel 2**  
**Del 2**



**3G.16 SL**

cod. 1144340

1144340\_3G16SL\_4 181119 FL



Dati tecnici Technical data Technische daten	Données techniques Datos técnicos Τεχνικά χαρακτηριστικά	Dados técnicos Technische gegevens Teknische data
----------------------------------------------------	----------------------------------------------------------------	---------------------------------------------------------

<b>Misure impiegabili mm</b> Usable lengths mm Gebrauchliche Längen mm	Mesures utilisables mm Medidas que se pueden emplear mm Διαστάσεις σε μμ	Medidas que se podem utilizar mm Te gebruiken engtes in mm Brugbare længder i mm	<b>4 ÷ 16</b>
------------------------------------------------------------------------------	--------------------------------------------------------------------------------	----------------------------------------------------------------------------------------	---------------

<b>Capacità caricatore n° punti</b> Magazine capacity No. of fasteners Magazinkapazität Nägel	Capacité chargeur n° de points Capacidad cargador n° puntos Δυνατότητα γεμιστέρα, σπινδύτερος	Capacidade carregador n° pontos Capaciteit magazijn in aantal spijkers Kapacitet af magasin antal klemme	<b>185</b>
-----------------------------------------------------------------------------------------------------	-----------------------------------------------------------------------------------------------------	----------------------------------------------------------------------------------------------------------------	------------

<b>Pressione d'esercizio</b> Working pressure Betriebsdruck	Pression de fonctionnement Presión de trabajo Πίεση λειτουργίας ατμ.	Pressao de trabalho Werkdruk Arbejds tryk bar	<b>4 ÷ 6 bar</b> <b>60 ÷ 90 psi</b>
-------------------------------------------------------------------	----------------------------------------------------------------------------	-----------------------------------------------------	----------------------------------------

<b>Consumo aria litri/colpo</b> Air consumption litres/shot Luftverbrauch Liter/Schlag	Consommation air litre/coup Consumo aire-litros/golpe Κατανοση αερα λ/ξτπημα	Consumo ar litro/golpe Luchtverbruik liter/schot Luftforbrug liter/skud	<b>0,18</b>
----------------------------------------------------------------------------------------------	------------------------------------------------------------------------------------	-------------------------------------------------------------------------------	-------------

<b>Peso kg</b> Weight kg Gewicht kg	Poids kg Peso kg Βαρος κγ	Peso kg Gewicht in kg Vægt kg	<b>1,00</b>
-------------------------------------------	---------------------------------	-------------------------------------	-------------

<b>Dimensioni (AxBxH) mm</b> Dimensions mm Größe mm	Dimension mm Dimensiones mm Δυνατότητα γεμιστέρα, σπινδύτερος	Dimencoes mm Afmetingen in mm Dimensioner mm	<b>223x43x198</b>
-----------------------------------------------------------	---------------------------------------------------------------------	----------------------------------------------------	-------------------

<b>EN 12549 :1999 ISO 11201 :1995</b> <b>Pressione sonora in pos. operatore</b> Sound pressure at the workstation Lärmintensität am Arbeitsplatz	Pression acoustique près de l'opérateur Presión sonora en posición encargado Ακουστική πίεση στη θέση χειριστού	Intensidade sonora perto do operador Geluidssterkte op de werkplek Lydstyrke på operatorposten	<b>83,5 dB(A)</b>
-----------------------------------------------------------------------------------------------------------------------------------------------------------	-----------------------------------------------------------------------------------------------------------------------	------------------------------------------------------------------------------------------------------	-------------------

<b>EN 12549 :1999 ISO 3744 :1994</b> <b>Potenza sonora emessa</b> Emitted sound power Ausgestrahlte Lärmintensität	Puissance acoustique émise Potencia sonora emitida Ακουστική ισχύς	Potência sonora emitida Uitgestraalde geluidssterkte Udsendt lydstryke	<b>88,7 dB(A)</b>
-----------------------------------------------------------------------------------------------------------------------------	--------------------------------------------------------------------------	------------------------------------------------------------------------------	-------------------

<b>EN 28662 :1992 ISO 5349 :1986 ISO 8662 -11</b> <b>Valore medio ponderato di vibrazione sull'impugnatura max.33 colpi</b> Weighted mean value of vibration on the grip max.33 shots Mitteler Vibrationswert, am Griff gemessen max.33 Schäge	Valeur moyenne pondérée de vibration mesurée sur la poignée max.33 coups Valor medio ponderado de vibracion medida en la empunadura max.33 golp Μεσος ορος μετρησης κραδασιον στη χειρολαβη μαξ.33 ξτπημα	Valor medio ponderado de vibracao medida no punho max.33 golpes Gewogen gemiddelde vibratiewaarde max.33 schot Middelvaerdi af vibrationer pa handtaget max.33 skud	<b>&lt;2,5 m/s²</b>
---------------------------------------------------------------------------------------------------------------------------------------------------------------------------------------------------------------------------------------------------------	-----------------------------------------------------------------------------------------------------------------------------------------------------------------------------------------------------------------	---------------------------------------------------------------------------------------------------------------------------------------------------------------------------	---------------------

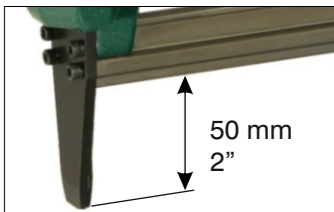

**Tipo di punto**  
Type of fastener  
Befestigungselement  
Type d'agrafe  
Tipo de punto  
Τυπος καρφιου  
Tipo de ponto  
Type nietjes  
Tilspændingstype

**3G**

0,55x0,75

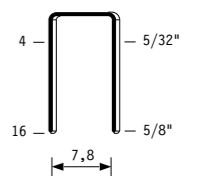

Crown: .350" (3/8")  
Gauge: 23

Parti di ricambio - Spare parts - Ersatzteile - Pièces de rechange - Piezas de repuesto  
Ανταλλακτικά - Partes sobresselentes - Wisselstukken - Reservedele

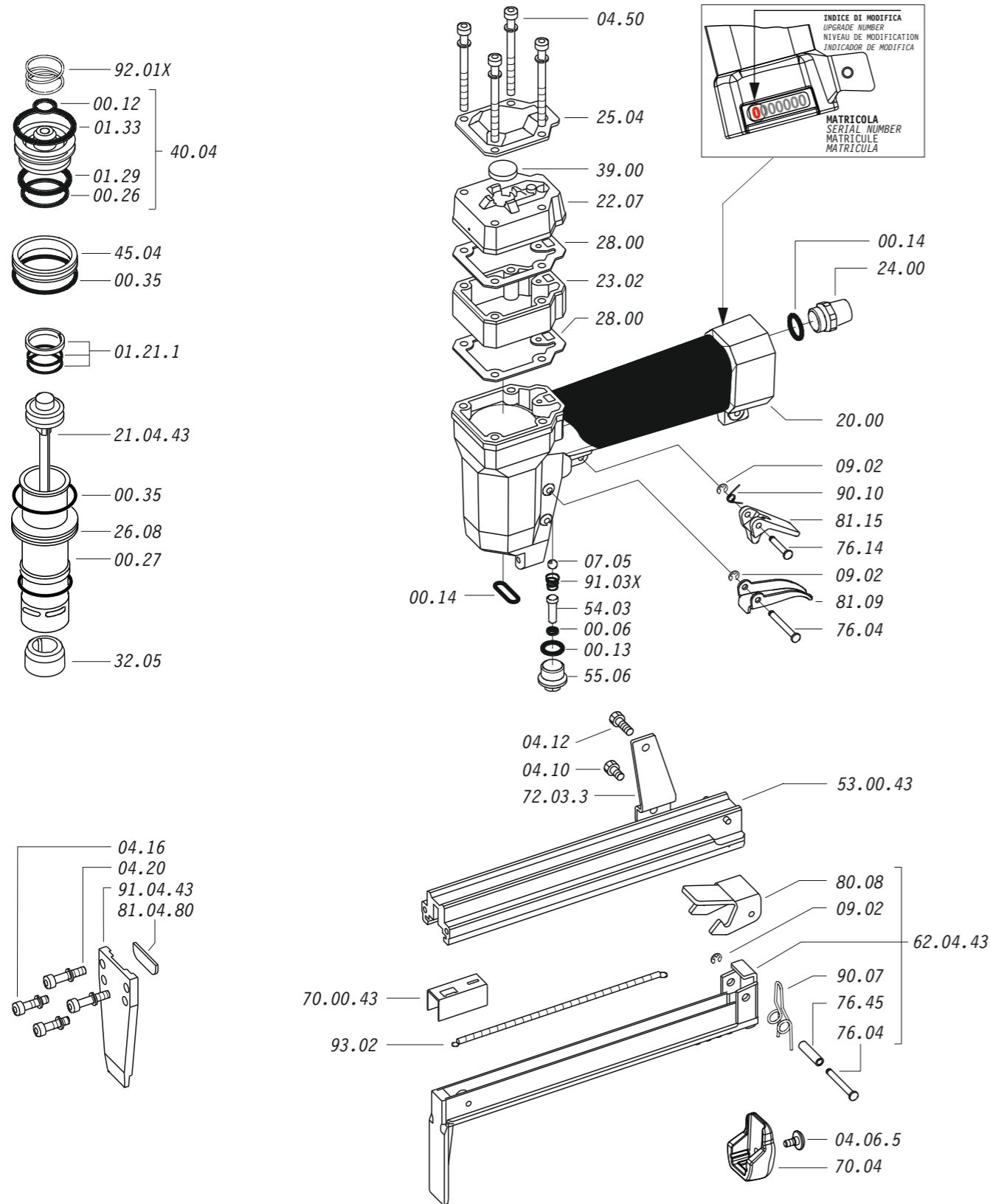

Dotazioni - Equipment - Ausrüstung - Équipements - Equipamiento - Παρεχόμενα  
Equipamento - Uitrusting - Udstyr

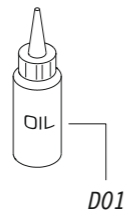

**3G.16 SL**

cod. 1144340

Parti di ricambio - Spare parts - Ersatzteile - Pièces de rechange - Piezas de repuesto  
Ανταλλακτικά - Partes sobresselentes - Wisselstukken - Reservedele

Cod.	Descrizione	Description
00.04	O-Ring	O-Ring
00.06	O-Ring	O-Ring
00.12	O-Ring	O-Ring
00.13	O-Ring	O-Ring
00.14	O-Ring	O-Ring
00.26	O-Ring	O-Ring
00.27	O-Ring	O-Ring
00.35	O-Ring	O-Ring
01.21.1	Guarnizione	Gasket
01.29	O-Ring	O-Ring
01.33	O-Ring	O-Ring
04.06.5	Vite	Screw
04.10	Vite	Screw
04.12	Vite	Screw
04.16	Vite	Screw
04.20	Vite	Screw
04.50	Vite	Screw
07.05	Sfera	Ball
07.30	Chiave esagonale	Hex. bar wrench
09.02	Anello elastico	Elastic ring
20.00	Corpo	Body
22.07	Testa	Head
23.02	Prolunga	Extension
24.00	Silenziatore	Silencer
25.04	Deflettore	Exhaust deflector
26.08	Cilindro	Cylinder
28.00	Guarnizione	Gasket
32.05	Ammortizzatore	Bumper
39.00	Guarnizione scarico	Exhaust gasket
40.04	Valvola completa	Valve ass'y
45.04	Anello valvola	Ring
54.03	Pulsante	Trigger valve
55.06	Raccordo	Bush
70.04	Protezione	Guard
72.03.3	Reggicaricatore	Support
76.04	Perno	Pin
76.14	Perno	Pin
76.45	Perno molla	Pin
80.08	Grilletto chiusura	Trigger
81.09	Grilletto comando	Trigger
81.15	Controgrilletto	Safety
90.07	Molla	Spring
90.10	Molla	Spring
91.03X	Molla	Spring
92.01X	Molla	Spring
93.02	Molla	Spring
21.04.43	Battente	Driver
53.00.43	Caricatore	Magazine
62.04.43	Carrello	Slider
70.00.43	Spingipunto	Pusher
81.04.80	Controtestina	Nose
91.04.43	Testina	Nose plate
D01	Bocchetta olio	Oiler

Guarnizioni - O-Rings - Dichtungen - Joints - Kit O-rings - Λαστιχάκια - Kit O-rings - Pakninger

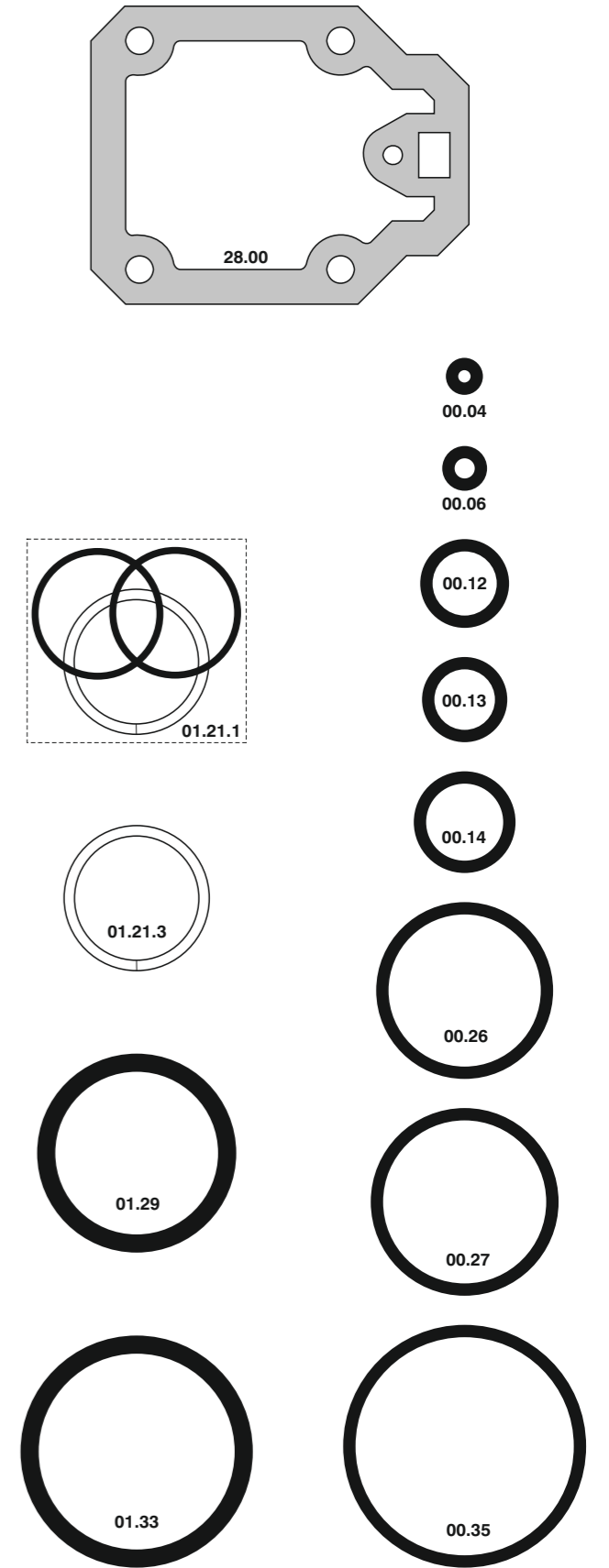

00.70.5

**3G.16 SL**

cod. 1144340

Indice di modifica  
Upgrade number

4